

# S323/S324

*High Precision Cleavers*

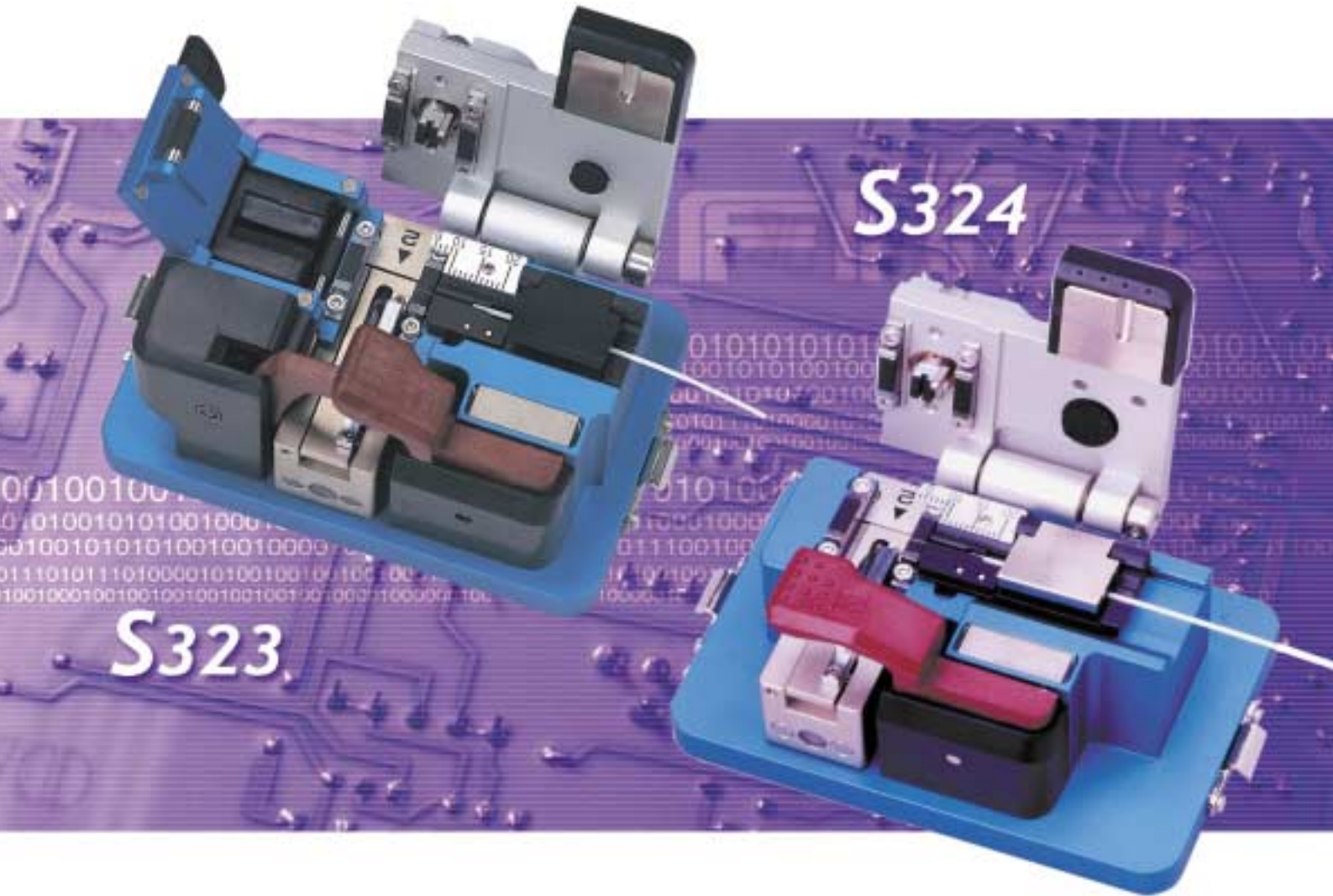

**FITEL**  
FURUKAWA ELECTRIC

# S323/S324 High Precision Cleavers

## Clean, Safe, Precise

Introducing Furukawa Electric's line of high precision three and four step cleavers. The S324 cleaver is an ergonomic, easy to use three step cleaver that replaces Fitel's well known S321 cleaver. The S324 is a smaller, "no frills" cleaver that produces consistent, high quality cleaves efficiently and quickly. Based on the S324 design, the S323 High Precision Cleaver incorporates a unique automatic waste fiber disposal system. This unique waste fiber collection system eliminates potentially hazardous waste fiber from the splice area and produces consistent high quality splicing.

### KEY FEATURES FOR S323 AND S324 HIGH PRECISION CLEAVERS

For S323 and S324:

- Cutting blade locks in place after scoring, preventing double scoring of fiber and also ensuring quality cleaving angles.
- Automatic cleave function provides constant cleaving pressure and improves cleave quality.

For S323 only:

- Waste fiber deposits automatically into a collection chamber, increasing cleaving efficiency by eliminating manual disposal and also eliminating

hazardous waste fiber in the work area environment.

- Easily removable collection chamber allows for safe and secure waste fiber disposal.

#### 4 step cleaving process

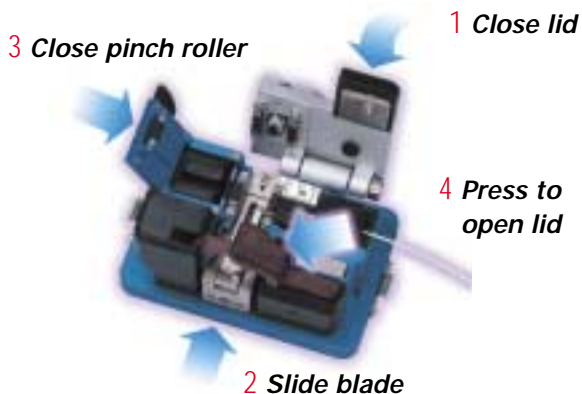

For S324 omit step 3.

### SPECIFICATIONS

#### Applicable Optical Fiber

Number of fibers: single fiber to 12-fiber ribbons (appropriate fiber holder is required for ribbons)

Clad diameter: 0.125mm

Coating diameter: 0.25mm and 0.9mm for single fiber; 0.3mm to 0.4mm thickness for ribbons

#### Cleave length

Type A: fixed length of 16mm or adjustable to 3–20mm with scale for single fiber; 10mm for ribbons

Type B: fixed length of 10mm or adjustable to 3–20mm with scale for single fiber; 10mm for ribbons

#### Dimensions

95mm (W) x 63mm (D) x 53mm (H)

height excludes rubber footings

#### Weight

S323: 570g, S324: 540g (including cover and attached fiber holder for single fiber)

#### Model

| Model Number                 | Waste Fiber Collection | Cleave Length |
|------------------------------|------------------------|---------------|
| (Refer to the Cleave Length) |                        |               |
| S323A                        | Available              | Type A        |
| S323B                        | Available              | Type B        |
| S324A                        | Not Available          | Type A        |
| S324B                        | Not Available          | Type B        |

#### Standard Package

| Description                | Model Number            |          | Quantity  |
|----------------------------|-------------------------|----------|-----------|
|                            | S323A/B                 | S324A/B  |           |
| Main Body                  | S323X-01                | S324X-01 | 1         |
| Cover                      | S323X-02                | S323X-02 | 1         |
| Collection Chamber         | S323X-03                | NA       | 2(1spare) |
| Collection Chamber (Large) | S323X-213               | NA       | 1         |
| Single Fiber Adaptor       | S323X-04                |          | 1         |
|                            | (for Model S323A/S324A) |          |           |
|                            | S323X-05                |          | 1         |
|                            | (for Model S323B/S324B) |          |           |

one of two is attached to the Mainbody

## THE FURUKAWA ELECTRIC CO., LTD.

### Head Office:

6-1, Marunouchi 2-chome  
Chiyoda-ku,  
Tokyo,  
100-8322 Japan  
Tel: +81 3 3286 3222  
Fax: +81 3 3286 3747  
www.furukawa.co.jp  
comsales@ho.furukawa.co.jp

### South East Asia:

Furukawa Electric Singapore Pte. Ltd.  
10 Anson Road #25-07/09  
International Plaza, Singapore 079903  
Tel: +65 6328 9896  
Fax: +65 6224 2362  
www.furukawa.com.sg  
admin@furukawa.com.sg

### Europe:

Furukawa Electric Europe Ltd.  
3rd Floor, Newcombe House  
43-45 Notting Hill Gate,  
London W11 3FE U.K.  
Tel: +44 20 7313 5320  
Fax: +44 20 7313 5310  
www.furukawa-fitel.co.uk  
sales@furukawa-fitel.co.uk

### North America:

Furukawa America Inc.  
200 Westpark Drive Suite 190  
Peachtree City, GA30269  
Tel: +1 770 487 1234  
O.S.P. Sales ext. 113  
O.E.M. Sales ext. 120  
www.fitelconn.com  
sales@fitelconn.com

### South America:

Furukawa Industrial S.A.  
Produtos Eletricos  
Rua Hasdrubal Bellegard, 820  
CIC-Curitiba-PR-Brazil  
81450-140  
Tel: +55 41 341 4342  
Fax: +55 41 341 3913  
www.furukawa.com.br  
sandro@furukawa.com.br

STR-02067

JE-162 1E2 TK 200